

B.TECH
(SEM V) THEORY EXAMINATION 2017-18
KINEMATICS OF MACHINES

Time: 3 Hours

Total Marks: 100

Note: 1. Attempt all Sections. If require any missing data: then choose suitably.

SECTION A

1. Attempt all questions in brief.

2 x10= 20

- a. Explain the terms: Lower pair, higher pair, Kinematic chain, and Inversion.
- b. Determine the mobility (degrees of freedom) of the mechanism shown in Fig.1

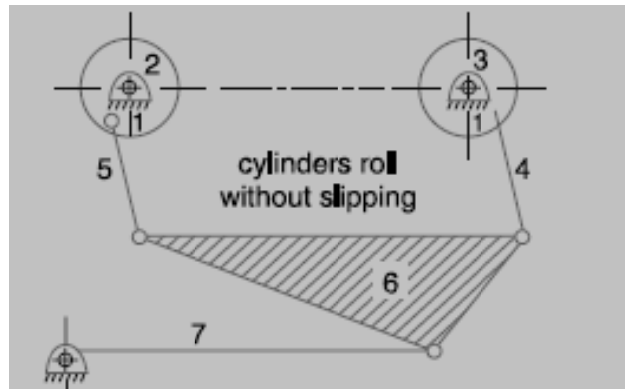

Fig.1

- c. Explain, with the help of a neat sketch, the space centrode and body centrode.
- d. Explain how the coriolis component of acceleration arises when a point is rotating about some other fixed point and at the same time its distance from the fixed point varies.
- e. Give a neat sketch of the straight line motion 'Hart mechanism'
- f. Which of the two assumptions-uniform intensity of pressure or uniform rate of wear
- g. Explain the phenomena of 'slip' and 'creep' in a belt drive.
- h. Distinguish between brakes and dynamometers.
- i. Define the following terms as applied to cam with a neat sketch:
 (a) Base circle, (b) Pitch circle, (c) Pressure angle, and (d) Stroke of the follower.
- j. State and prove the law of gearing.

SECTION B

2. Attempt any three of the following:

10x3 = 30

- a. In a crank and slotted lever quick return motion mechanism, the distance between the fixed centers is 240 mm and the length of the driving crank is 120 mm. Find the inclination of the slotted bar with the vertical in the extreme position and the time ratio of cutting stroke to the return stroke. If the length of the slotted bar is 450 mm, find the length of the stroke if the line of stroke passes through the extreme positions of the free end of the lever.

- b. Locate all the instantaneous centers for the crossed four bar mechanism as shown in Fig.2. The dimensions of various links are: $CD = 65$ mm; $CA = 60$ mm; $DB = 80$ mm; and $AB = 55$ mm. Find the angular velocities of the links AB and DB , if the crank CA rotates at 100 r.p.m. in the anticlockwise direction.

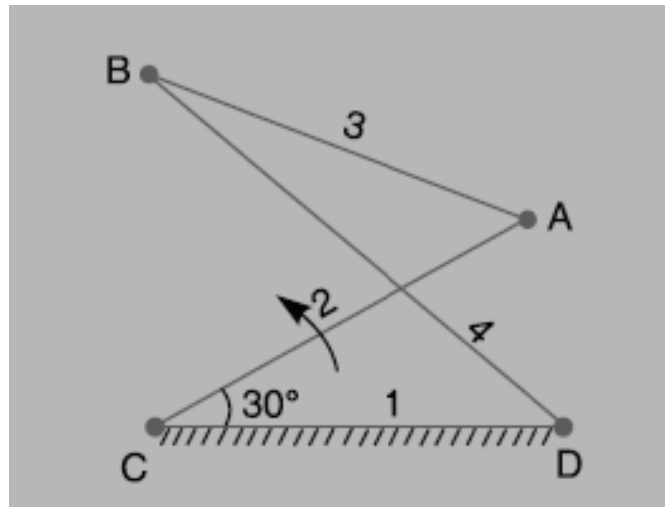

Fig.2

- c. In a quick return mechanism, as shown in Fig.3, the driving crank OA is 60 mm long and rotates at a uniform speed of 200 r.p.m. in a clockwise direction. For the position shown, find
1. Velocity of the ram R
 2. Acceleration of the ram R , and
 3. Acceleration of the sliding block A along the slotted bar CD .

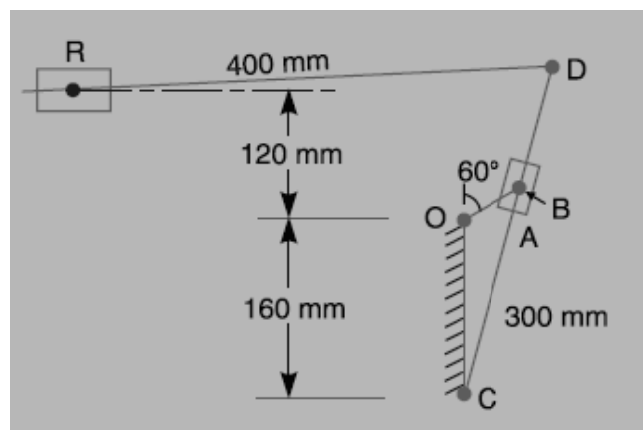

Fig.3

- d. A conical pivot bearing 150 mm in diameter has a cone angle of 120° . If the shaft supports an axial load of 20 kN and the coefficient of friction is 0.03, find the power lost in friction when the shaft rotates at 200 r.p.m., assuming
1. Uniform pressure and
 2. Uniform wear
- e. A simple band brake is operated by a lever of length 500 mm. The brake drum has a diameter of 500 mm and the brake band embraces $5/8$ of the circumference. One end of the band is attached to the fulcrum of the lever while the other end is attached to a pin on the lever 100 mm from the fulcrum. If the effort applied to the end of the lever is 2 kN and the coefficient of friction is 0.25, find the maximum braking torque on the drum.

SECTION C

3. Attempt any *one* part of the following:

10 x 1 = 10

- (a) A toggle press mechanism, as shown in Fig.4, has the dimensions of various links as follows : $OP = 50$ mm ; $RQ = RS = 200$ mm ; $PR = 300$ mm. Find the velocity of S when the crank OP rotates at 60 r.p.m. in the anticlockwise direction. If the torque on P is 115 N-m, what pressure will be exerted at S when the overall efficiency is 60 percent.

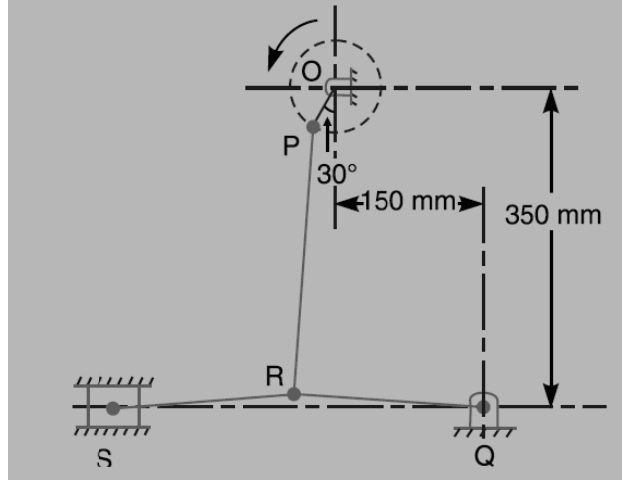

Fig.4

- (b) State and prove the ‘Aronhold Kennedy’s Theorem’ of three instantaneous centres.

4. Attempt any *one* part of the following:

10 x 1 = 10

- (a) Draw the acceleration diagram of a slider crank mechanism.
- (b) A Hooke’s joint connects two shafts whose axes intersect at 150° . The driving shaft rotates uniformly at 120 r.p.m. The driven shaft operates against a steady torque of 150 N-m and carries a flywheel whose mass is 45 kg and radius of gyration 150 mm. Find the maximum torque which will be exerted by the driving shaft.

5. Attempt any *one* part of the following:

10 x 1 = 10

- (a) In a screw jack, the helix angle of thread is α and the angle of friction is ϕ . Show that its efficiency is maximum, when $2\alpha = (90^\circ - \phi)$.
- (b) What is the difference between absorption and transmission dynamometers? What are torsion dynamometers?

6. Attempt any *one* part of the following:

10x 1 = 10

- (a) Draw the profile of a cam with oscillating roller follower for the following motion :
- (a) Follower to move outwards through an angular displacement of 20° during 120° of cam rotation.
 - (b) Follower to dwell for 50° of cam rotation.
 - (c) Follower to return to its initial position in 90° of cam rotation with uniform acceleration and retardation.
 - (d) Follower to dwell for the remaining period of cam rotation.
- The distance between the pivot centre and the roller centre is 130 mm and the distance between the pivot centre and cam axis is 150 mm. The minimum radius of the cam is 80 mm and the diameter of the roller is 50 mm.

- (b) Draw the displacement, velocity and acceleration diagrams for a follower when it moves with simple harmonic motion. Derive the expression for velocity and acceleration during outstroke and return stroke of the follower.

7. Attempt any *one* part of the following:

10 x1 = 10

- (a) A compound epicyclic gear is shown diagrammatically in Fig.5. The gears *A*, *D* and *E* are free to rotate on the axis *P*. The compound gear *B* and *C* rotate together on the axis *Q* at the end of arm *F*. All the gears have equal pitch. The number of external teeth on the gears *A*, *B* and *C* are 18, 45 and 21 respectively. The gears *D* and *E* are annular gears. The gear *A* rotates at 100 r.p.m. in the anticlockwise direction and the gear *D* rotates at 450 r.p.m. clockwise. Find the speed and direction of the arm and the gear *E*.

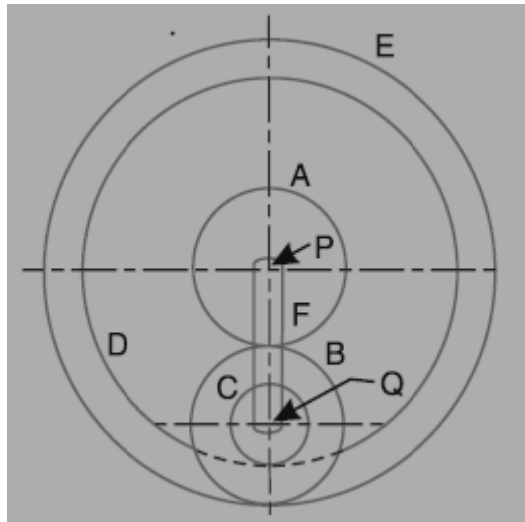

Fig.5

- (b) Explain briefly the differences between simple, compound, and epicyclic gear trains. What are the special advantages of epicyclic gear trains?