

- (b) Explain the basic principle of SMPS. List the merits and demerits.
- (c) Draw the internal circuit of an off the shelf bipolar OTA and explain its working.

5 Answer any **two** of the following : 10×2=20

- (a) Explain the working of the following circuit :

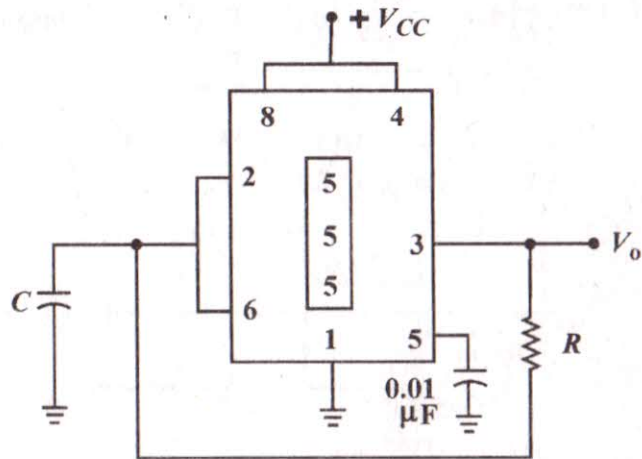

- (b) It is required to generate a frequency  $4f$  from an input frequency of  $f$ . Suggest a circuit and explain its working.
- (c) Design an OP-AMP based amplifier to give a voltage gain of 2, 3, 5 and 9 depending upon the status of 2 digital inputs  $X_1$  and  $X_2$ .



(Following Paper ID and Roll No. to be filled in your Answer Book)

PAPER ID : 3086

Roll No.

**B.Tech**

(SEM V) ODD SEMESTER THEORY EXAMINATION 2009-10  
ANALOG INTEGRATED CIRCUITS

Time : 3 Hours]

[Total Marks : 100

Note : Attempt all questions.

1 Answer any **two** of the following : 10×2=20

- (a) Derive the expression for  $I_0$  in the following circuit.

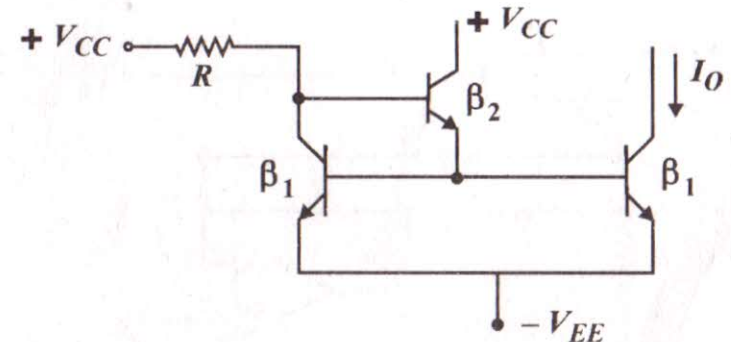

Also find the output impedance.

- (b) Draw the output stage of a 741-C op-amp and explain how it protects the op-amp against short circuit. Also derive the output impedance.

- (c) Explain the working of a CC level shifter and give proper reasons as to why the lower resistance in emitter is replaced by a current mirror.

2 Answer any **two** of the following : 10×2=20

- (a) Design a 741-C based INV amplifier for  $A_v = -20$  such that the circuit offers maximum input impedance. Given

$$V_{os(max)} = 6 \text{ mV} \text{ and } (R_1 || R_2)$$

$$I_{os(max)} = 9 \text{ mV} \text{ where}$$

$$I_{os(max)} = 260 \text{ nA.}$$

- (b) Calculate  $V_0$  in the following circuit :

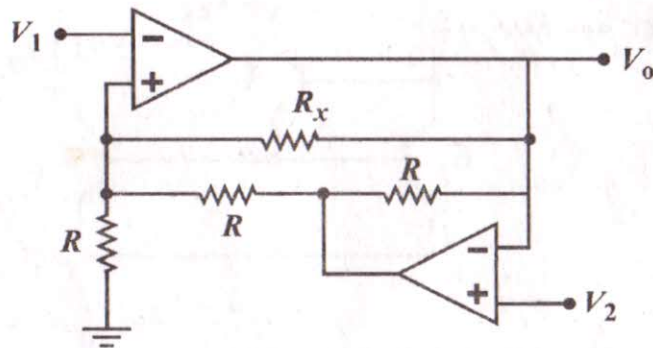

- (c) Design a biquad filter with  $f_0 = 8 \text{ kHz}$ ,  $BW = 250 \text{ Hz}$  and a 20-dB response gain. What is the value of  $H_{OLP}$  ?

3 Answer any **two** of the following : 10×2=20

- (a) Explain the working of the following circuit and draw its output wave form if input is a  $\pm 5 \text{ V}$  sine. Assume  $D_1, D_2$  to be ideal.

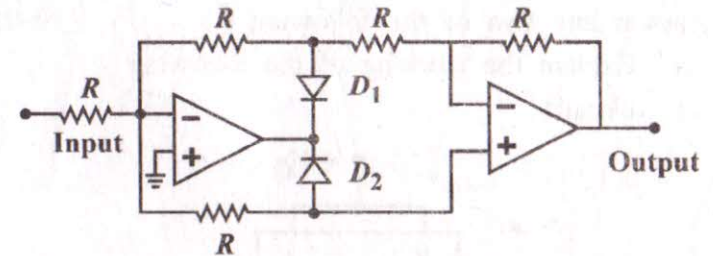

- (b) It is required to generate the following waveform using an OP-AMP.

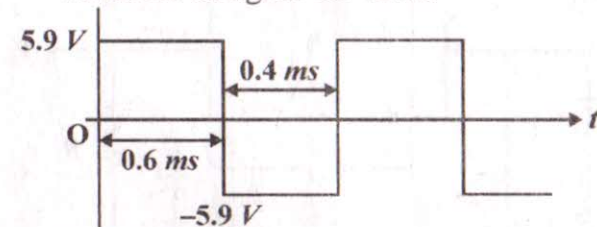

Design a circuit.

- (c) Draw an OP-AMP based Monostable multivibrator and explain its working.

4 Answer any **two** of the following : 10×2=20

- (a) Design a LM 723 based voltage regulator with following parameters :

- (i) Input voltage (16V-20V)
- (ii) Output voltage = 6V
- (iii)  $I_{L(max)} = 250 \text{ mA}$
- (iv)  $I_{sc} = 75 \text{ mA}$

